

Nuclear Power Industry

Modeling of the start-up of a two-shaft High Temperature Gas-Cooled Reactor (HTGR)

Introduction

This case study demonstrates the modeling of the start-up of the High Temperature Gas-Cooled Reactor (HTGR) nuclear power plant (NPP) discussed in the case study titled “Steady-State Simulation of a Two-shaft High-Temperature Gas-Cooled Reactor Nuclear Power Plant.”

System Description

The configuration that is considered in this example is a direct two-shaft closed inter-cooled recuperated Brayton cycle as shown in Figure 1. The heat source for the system is a Pebble Bed Reactor [1,2].

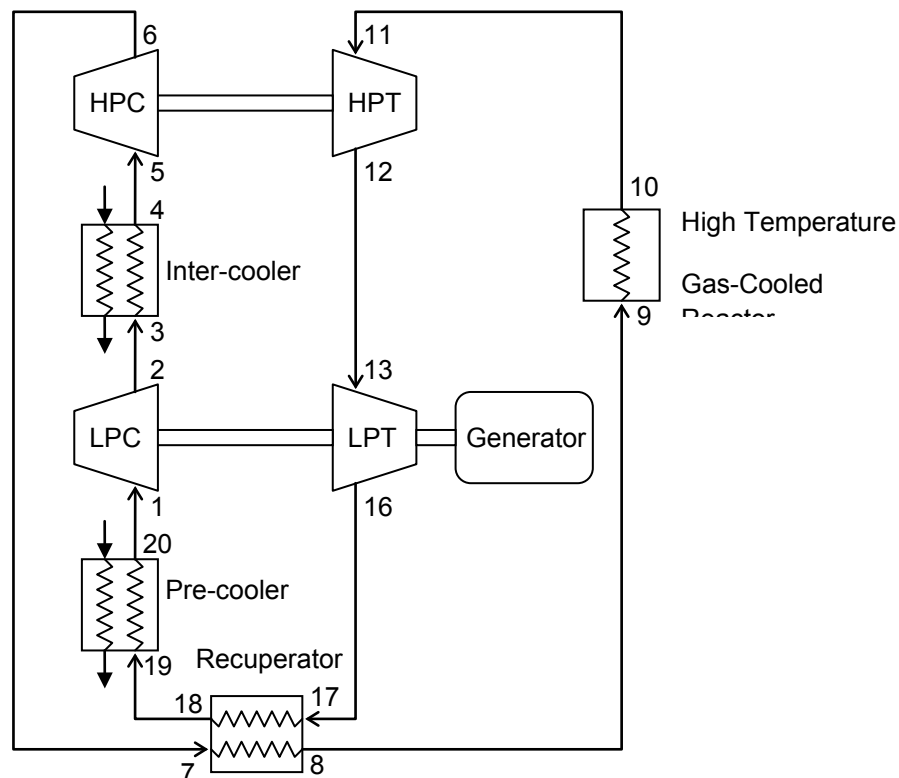

Figure 1: Schematic layout of a two-shaft Power Conversion Unit (PCU) for a Pebble Bed type HTGR.

The operation of the cycle is discussed in [3] and in case study titled “Steady-State Simulation of a Two-shaft High-Temperature Gas-Cooled Reactor Nuclear Power Plant.”

Objective of simulation

The objective of the simulation is to model the start-up of the system.

Flownex model

The Flownex model of the system is shown in Figure 2.

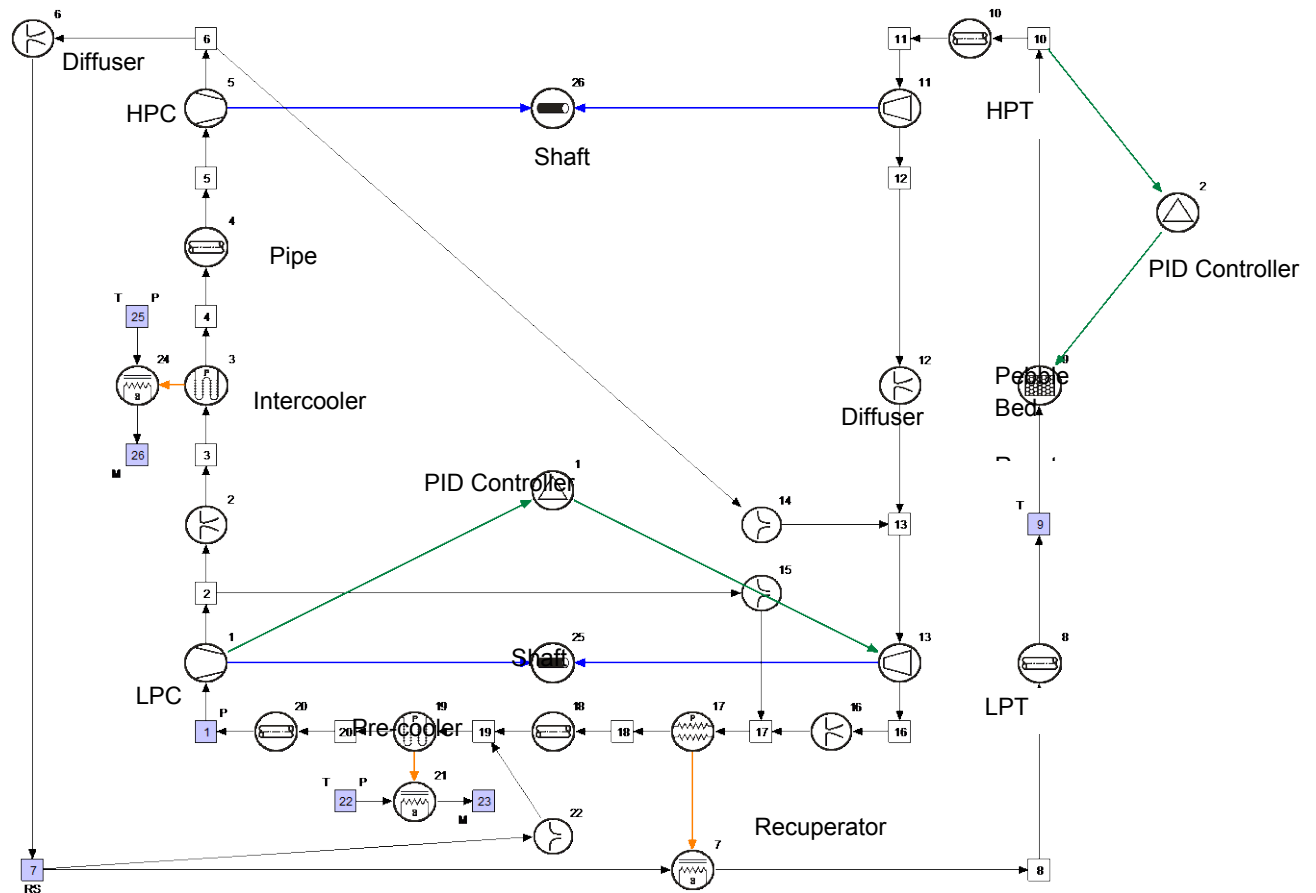

Figure 2: Flownex network of the direct two-shaft closed inter-cooled recuperated Brayton cycle PBMR power plant.

Two PID controllers are employed to control the start-up of the system. The first one senses the speed of the LPC/LPT shaft and then adjusts the power of the generator load on the shaft in such a way that the generator initially acts as a motor that drives the shaft and then switches over to a generator load that approaches the design point value as the speed of the shaft approaches the design speed. The second PID controller senses the reactor exit temperature and adjusts the control rod position in an attempt to keep the reactor exit temperature constant.

Determination of input parameters for PID controllers

The input parameters for the shaft speed PID controller were determined as follows: Starting at near zero shaft speeds the speed of the LPC/LPT shaft was slowly ramped up using Flownex's event editor while the speed of the HPC/HPT shaft was calculated using Flownex's shaft model. According to this model

$$\frac{d\omega}{dt} = \frac{P}{I\omega} \quad (1.1)$$

where

- ω = angular speed,
- I = moment of inertia of shaft together with all components attached to the shaft and

P = net power delivered to the shaft.

The net power delivered to the shaft is given by

$$P = \eta_{mech} \sum P_{turbine} - \sum P_{compressor} - P_{gen} / \eta_{gen} \quad (1.2)$$

where

η_{mech} = shaft mechanical efficiency,

η_{gen} = generator efficiency,

$P_{turbine}$ = turbine fluid power,

$P_{compressor}$ = compressor fluid power and

P_{gen} = generator power.

The net fluid power to the shaft is given by

$$P_{fluid} = \eta_{mech} \sum P_{turbine} - \sum P_{compressor} \quad (1.3)$$

A plot of net fluid power during the ramp-up transient is shown in Figure 3.

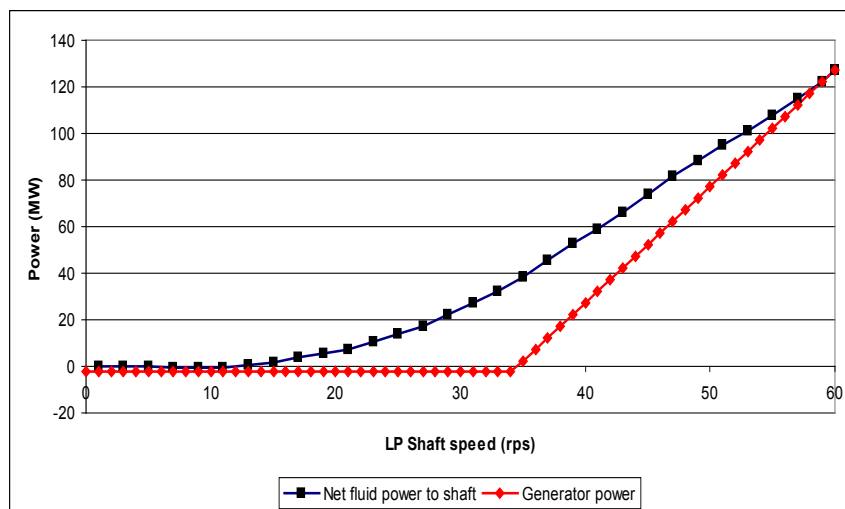

Figure 3: Variation in P_{fluid} and controller imposed generator power with speed.

The input parameters of the PID controller are now set in such a way that it gives a variation of generator power with speed as shown in Figure 3. The difference $P_{fluid} - P_{gen} / \eta_{gen}$ is the net fluid power to the shaft that will be used to accelerate the LPC/LPT shaft. Important to notice is that the generator power is negative up to a shaft speed of about 34 rps. During this stage of the start-up the generator will therefore act as a motor.

Description of simulation

The initial condition for the startup simulation is the steady-state solution for a shaft speed of 1 Hz for both the HP and LP shafts. The boundary condition for the initial steady-state simulation is a fixed pressure of 3610 kPa at Node 1 and a reactor outlet temperature of 900 °C. The pressure

boundary condition at Node 1 was determined through trial and error to give a pressure of 2333.3 kPa after the system has reached full power design point operation. At the start of the transient simulation the fixed pressure condition at Node 1 is released while the total mass in the system is kept constant.

With the PID controller that causes the generator to act as a motor up to a speed of about 34 rps the LPC/LPT shaft quickly spins up to design speed with the design generator load applied to the shaft at the design speed.

More details on the simulation can be found in [3].

Results

Figure 4 to Figure 9 show the variation of pressures, temperatures, mass flows, shaft speed, generator power and maximum fuel temperature during startup.

Figure 10 and Figure 11 show the locus plots of the HPC and LPC operating points on the compressor characteristics. While the operating point of the HPC stays well clear of the surge line, the operating point of the LPC at low speeds falls within the surge region. This is undesirable and it is an issue that warrants further investigation. What this however demonstrates is that one can not select component characteristics with only steady-state operation in mind. One also has to take the impact of component characteristics on system performance during operational transients into account. This is a task where systems CFD analysis is very helpful.

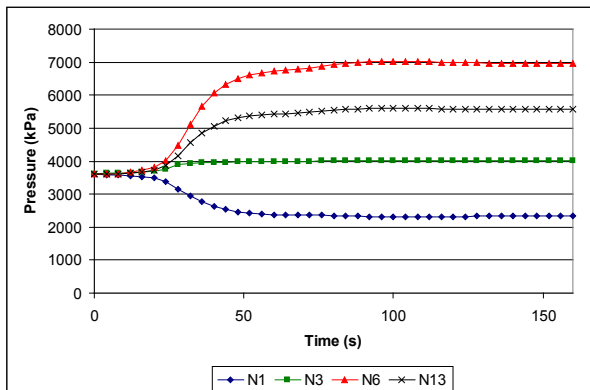

Figure 4: Variation of pressures.

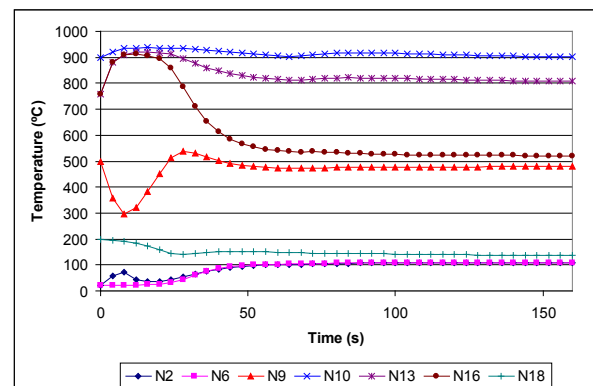

Figure 5: Variation of temperatures.

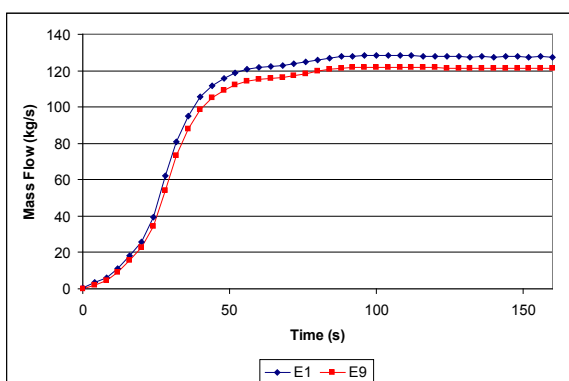

Figure 6: Variation of mass flows.

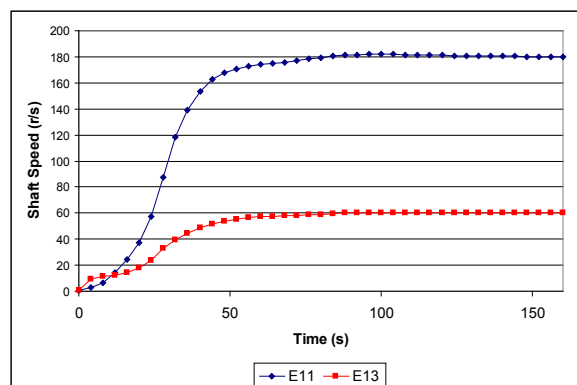

Figure 7: Variation of shaft speeds.

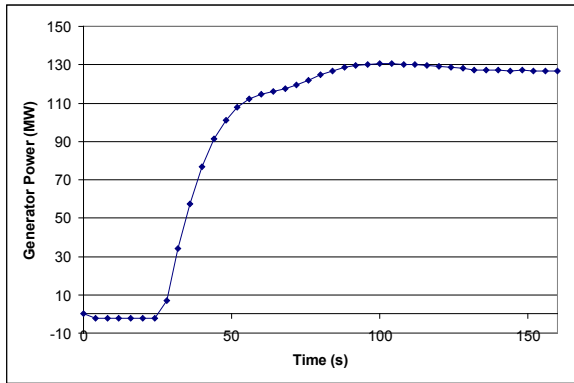

Figure 8: Variation of generator power.

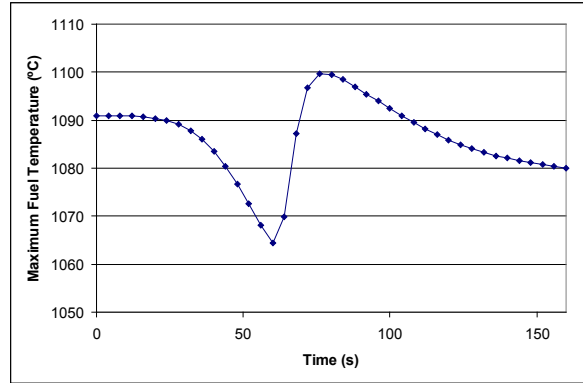

Figure 9: Maximum fuel temperature.

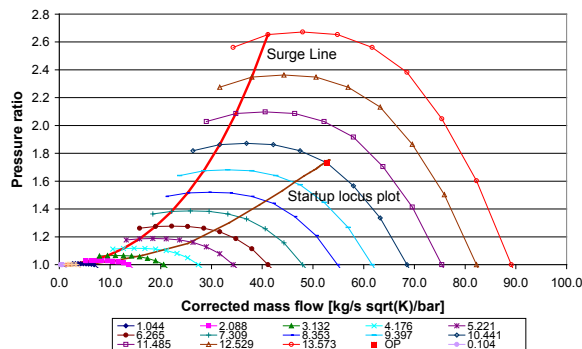

Figure 10: Locus plot of HPC operating point.

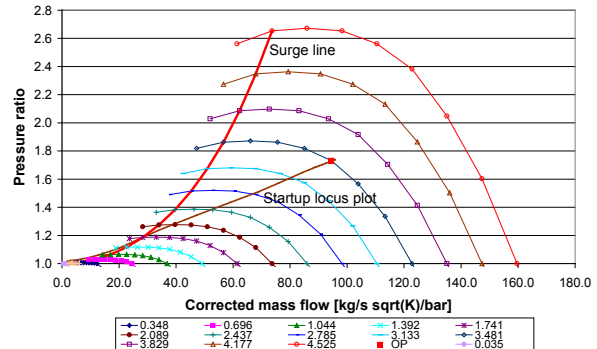

Figure 11: Locus plot of LPC operating point.

Conclusion

Flownex was used to design a controller for the start-up of a HTGR NPP that varies the generator power as function of shaft speed. Using this controller the whole start-up process was modeled. A problem was identified with the surge of the LPC during start-up that warrants further investigation.

References

- [1] Rousseau, P.G., and Greyvenstein, G.P., 2003, "Changing the face of nuclear power via the innovative Pebble Bed Modular Reactor", Proceedings of Power Generation World, 16-17 March 2004, Gallagher Estate, Midrand, South Africa. (Available on Flownex website under Publications).
- [2] PBMR Website. www.pbmr.co.za.
- [3] "Two-shaft direct Brayton Cycle HTGR Demo" under Downloads on Flownex Website.

Flownex® International,
Global Headquarters
+27 (0) 18 297 0326/7
www.flownex.com



Australia	+61 3 8790 1087	Poland	+27 11 782 3895
China	2 164 821 011	Singapore	+65 67 32 9818
Greece	+30 231 0 251 731	South Africa	+27 12 809 9500
India	+91 08 042 151 310	Turkey	+90 312 432 37 85
Israel	+972 3 920 6303	United Kingdom & Europe	+44 08 450 772 810
Japan	+81 44 230 5121	United States & Canada	+11 (781) 993-9003
Korea	+82 22 051 2305		